

22341

22232

4 Hours / 70 Marks

Seat No.

--	--	--	--	--	--	--	--

- Instructions :**
- (1) All Questions are *compulsory*.
 - (2) Illustrate your answers with neat sketches wherever necessary.
 - (3) Figures to the right indicate full marks.
 - (4) Assume suitable data, if necessary.
 - (5) Use of Non-programmable Electronic Pocket Calculator is permissible.
 - (6) Mobile Phone, Pager and any other Electronic Communication devices are not permissible in Examination Hall.

Marks

1. Attempt any FIVE of the following :

10

- (a) Draw the conventional representation of the following :
 - (i) Bearings
 - (ii) Compression spring with square section
- (b) Two mild steel plates of 8 mm thickness are to be welded to have lap joint by a fillet weld of leg length 8 mm. Represent the weld on drawing with proper symbols.
- (c) Draw the conventional representation of :
 - (i) Spur gear
 - (ii) Worm and worm wheel
- (d) Draw the actual view and conventional representation of the following :
 - (i) Internal screw thread
 - (ii) Splined shaft



- (e) Draw the symbol for representing the geometrical tolerance in case of the following :
- Concentricity
 - Surface profile
- (f) State the meaning of the symbol shown in Fig. 1

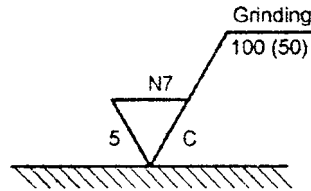

Fig. 1

- (g) Refer Fig. 2 and state the meaning of symbol at 'x' and 'y'.

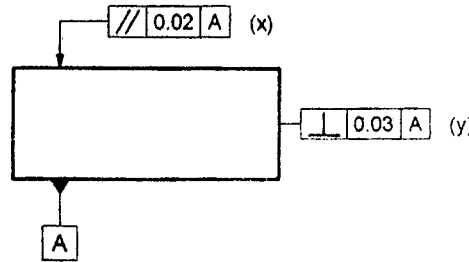

Fig. 2

2. Attempt any TWO of the following :

12

- A vertical square prism 60 mm sides of base and height 100 mm has its base on H.P. and rectangular faces equally inclined to V.P. It is penetrated by a horizontal square prism 45 mm sides and axis 100 mm such that axes bisect each other. The faces of the horizontal prism are equally inclined to H.P. Draw the three views of solids showing lines of intersection.
- A vertical cylinder of 70 mm diameter is penetrated by another cylinder of 50 mm diameter. The axis of the penetrating cylinder is parallel to both H.P. and V.P. and is 6 mm away from the axis of the vertical cylinder. Draw the projection showing curves of intersection. (Assume axis length for both cylinders)
- A cone with base diameter 70 mm and axis height 65 mm is kept on the H.P. on its base. It is penetrated by a horizontal cylinder of diameter 30 mm with its axis parallel to V.P. and intersecting the axis of the cone at a distance of 20 mm above the base of the cone. Draw the projections of solids showing curves of intersection.

3. (A) Attempt any ONE of the following : 4

- (a) Write the symbol for light press fit and give its two applications.
 (b) The shaft has size $\phi 40^{+0.05}$ and hole is $\phi 40^{+0.00}$. Determine the type of fit.

(B) Attempt any TWO of the following : 12

- (a) A right circular cone having diameter of base 40 mm, axis length 60 mm resting on its base on H.P. is cut by an AIP at 45° to H.P. and bisecting the axis. Draw the DLS of the cone.
 (b) Draw the development of Part 'P' of a truncated right circular cylinder shown in Fig. 3.

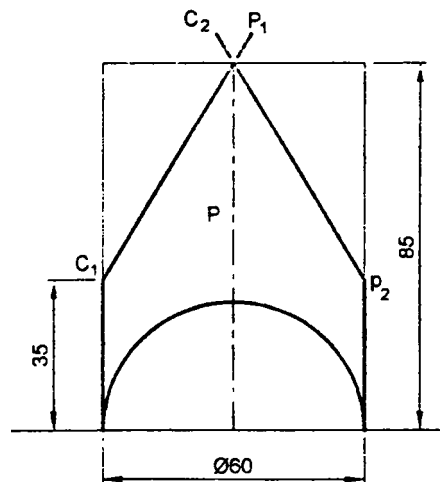

Fig. 3

- (c) Draw the development of lateral surface of the elbow joint of two pipes shown in Fig. 4.

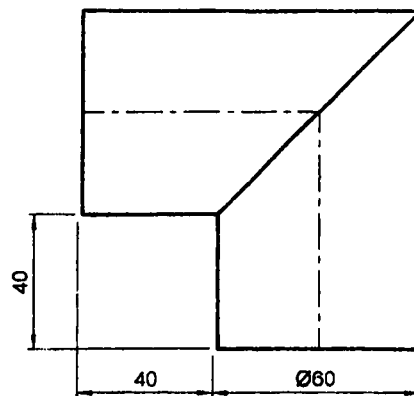
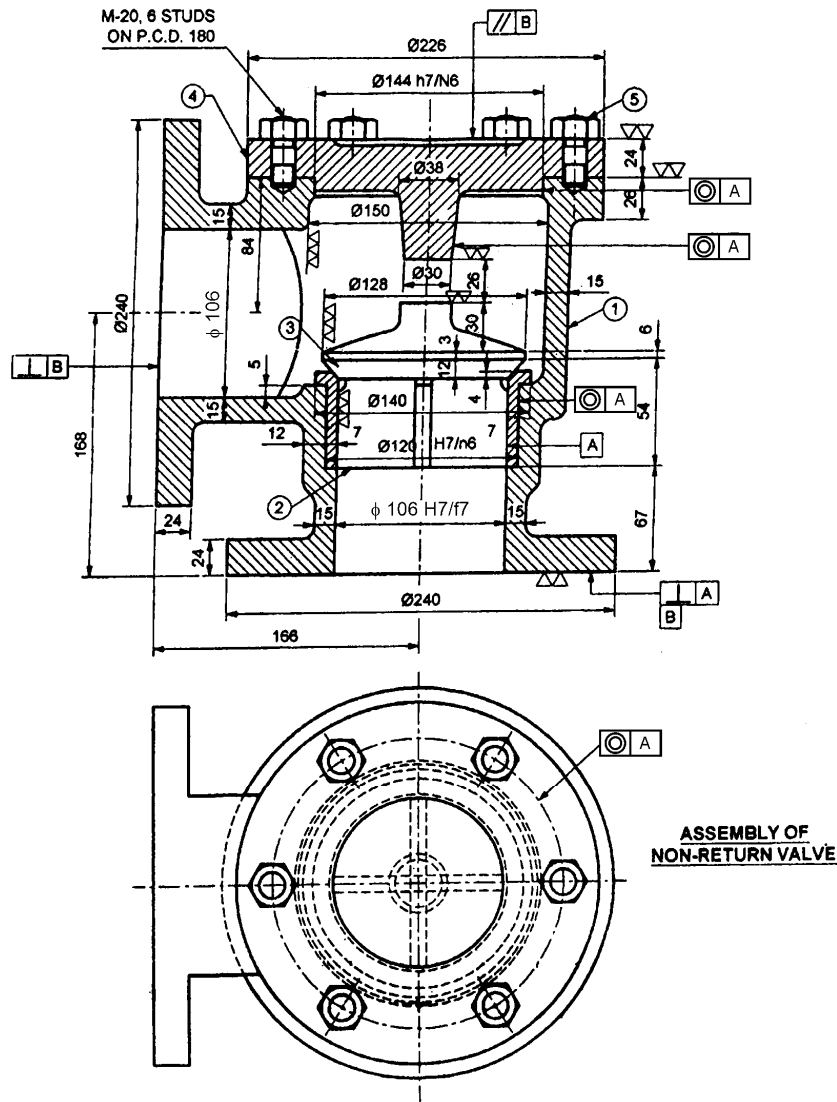

Fig. 4

4. Attempt the following :

Fig. 5 shows the assembly of non-return valve. Draw the detailed drawing of following parts :



FIT CHART

106H7/f7 = CLEARANCE FIT
144H7/h6 = CLEARANCE FIT
120H7/k6 = CLEARANCE FIT

PART LIST

PART NO.	PART NAME	MATERIAL	QTY.
1	BODY	C.I.	1
2	VALVE SEAT	G.M.	1
3	VALVE	G.M.	1
4	COVER	C.I.	1
5	STUD WITH NUT	M.S.	4

Fig. 5

- (i) Body – Sectional FV and TV
- (ii) Valve – F.V. and T.V.
- (iii) Valve seat – F.V. and T.V.
- (iv) Indication of Tolerance, geometrical tolerance etc.

5. Attempt any ONE of the following :

(a) Fig.- 6 shows details of Screw Jack. Draw sectional F.V. and T.V. of the assembly. Prepare bill of material.

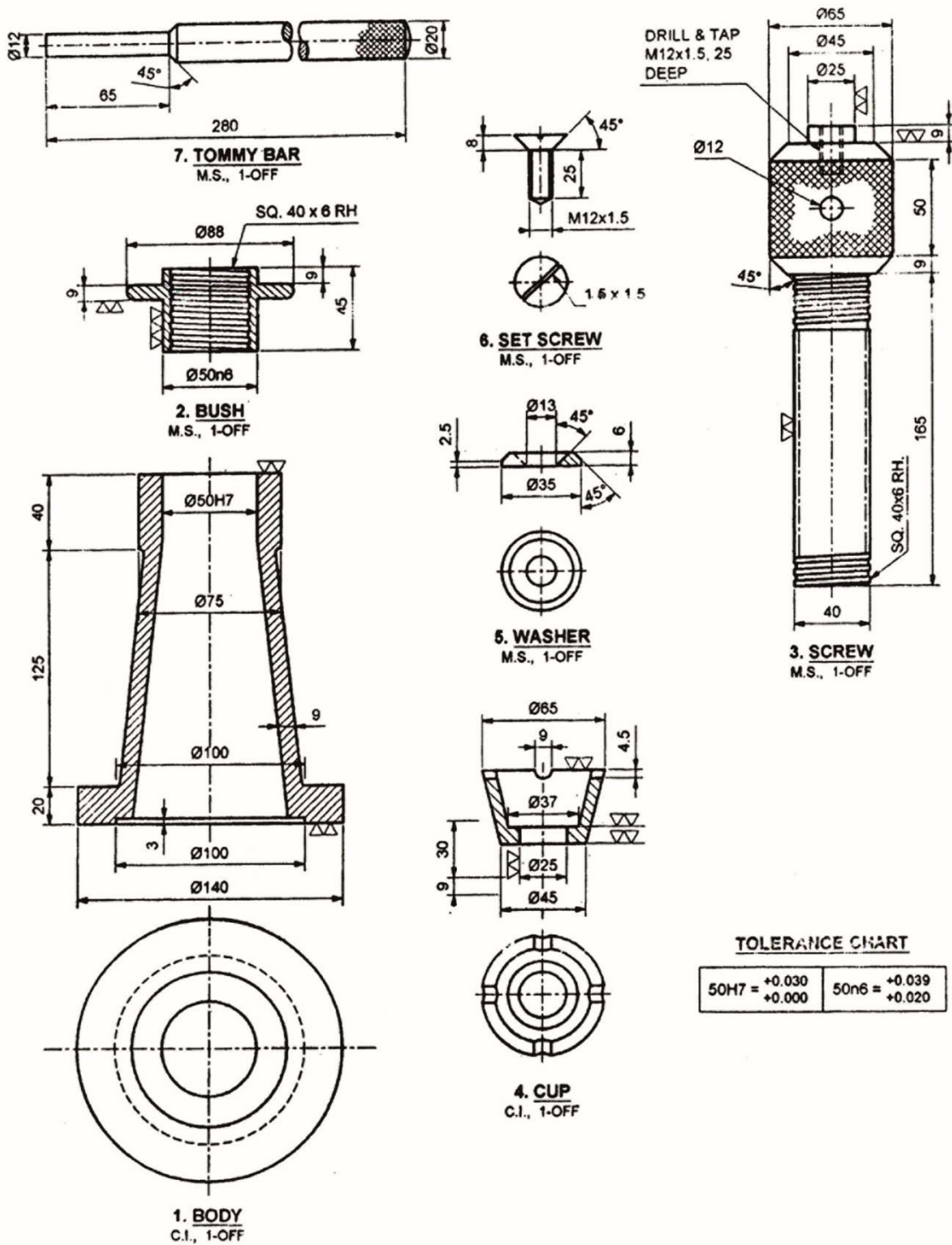

Fig. 6

(b) Fig. – 7 shows the details of the universal coupling. Draw the following views of assembly.

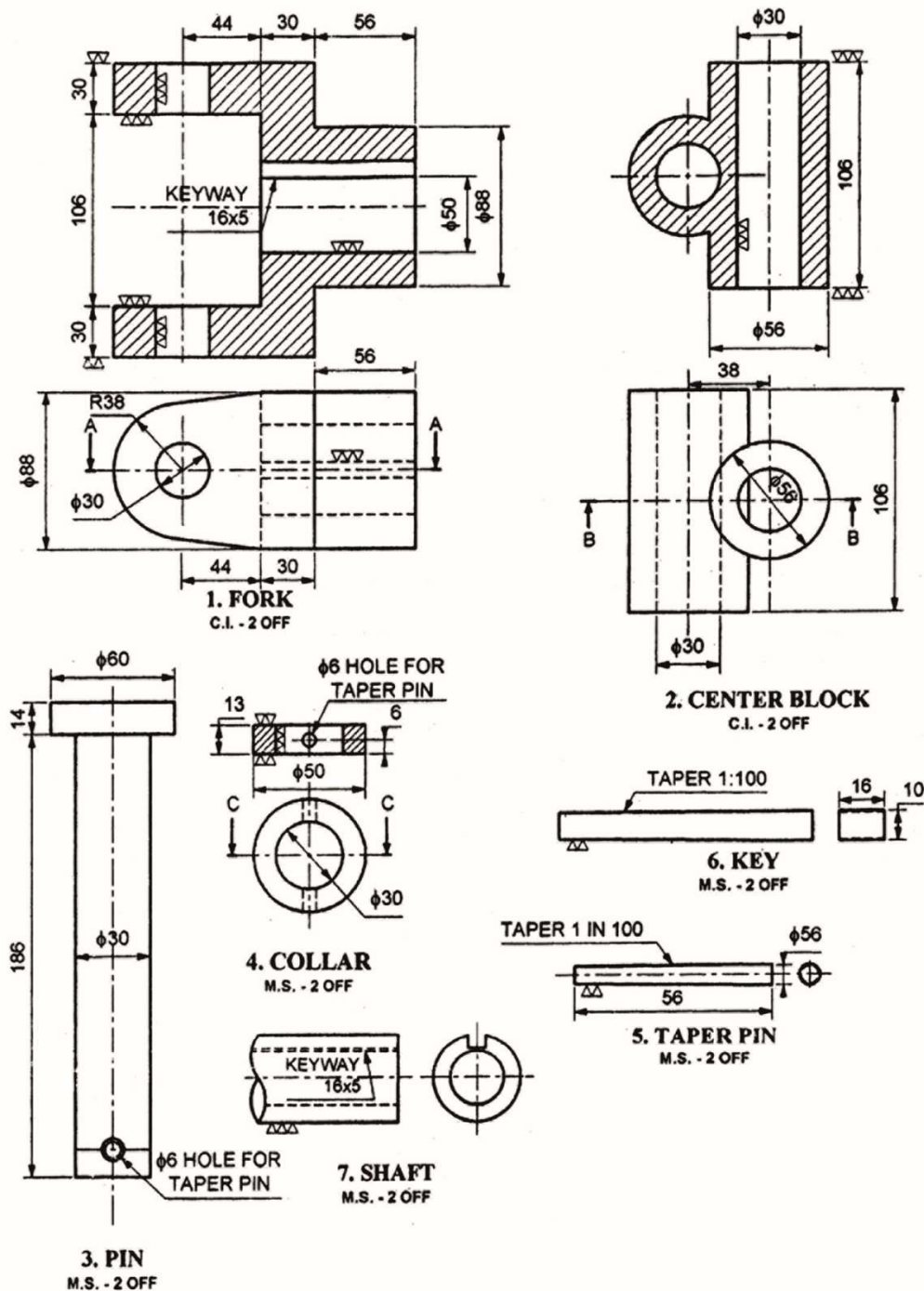

Fig. 7

22341

[7 of 8]

- (i) Sectional Front View
 - (ii) Top view
 - (iii) Prepare bill of material.
-

